

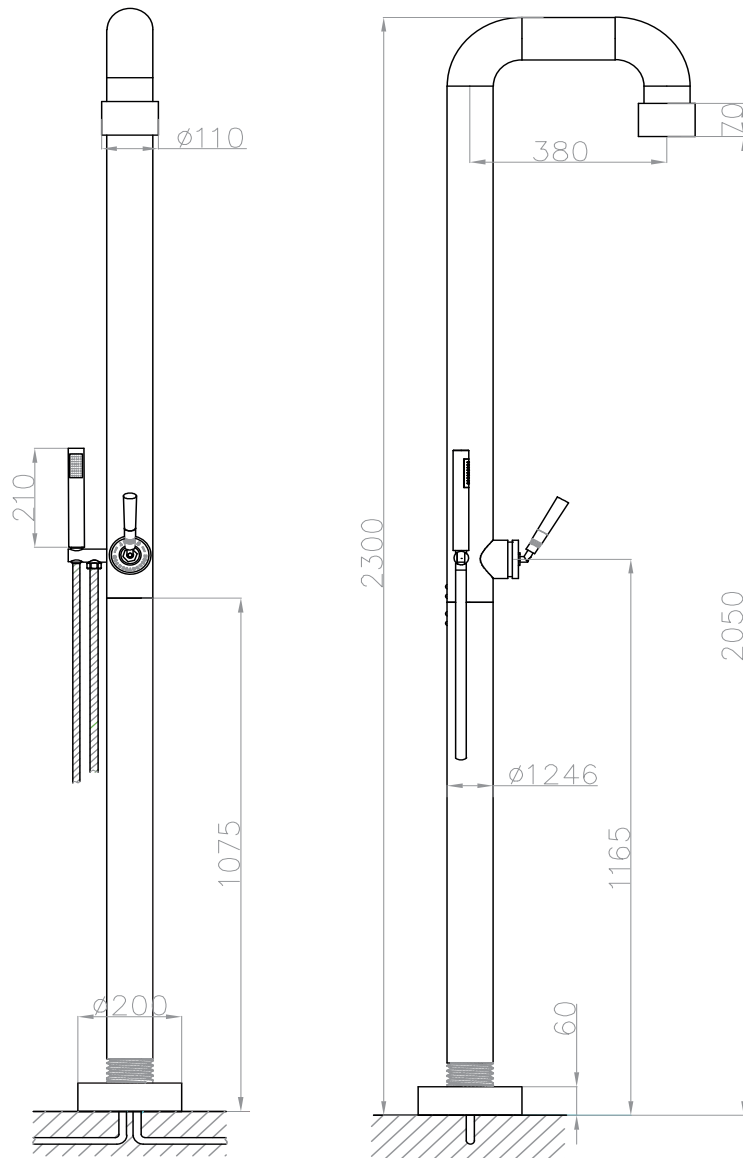

JEE-O soho shower 02 specifications

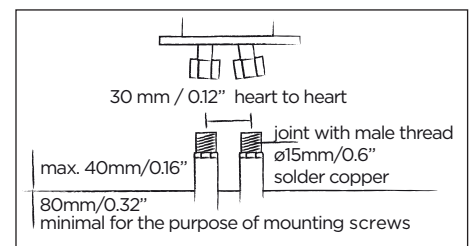

Note:
UV radiation and extreme temperature can affect the color and structure of the JEE-O soho shower 02 surface.

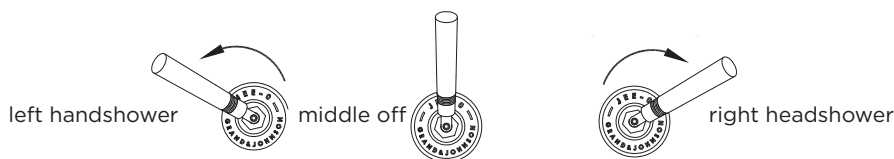

Article code:

700-6210
● Brushed stainless steel - **RAW**

700-6212
● Hammercoated black matt

700-6218 green RAL 6003
● Powder coating matt

700-6219 grey RAL 7040
● Powder coating matt

Material:

Stainless Steel r304

Coating:

hammercoat black (1.5) Electro powder spray

Cartridge:

Kerox ceramic mixing mechanism (progressive), item code **005-0203**

Cleaning:

cleaning vinegar or alcohol

Flexhose:

150 cm length

Flow at water of 38°C / 100,4°F:

10l / 2,6gal p/m at 3bar pressure

Connection:

2 x G 1/2" ($\phi 15\text{mm} / 0.6"$)
nylon^(out)/epdm⁽ⁱⁿ⁾ flexhose
with brass swivel
British Standard Pipe (BSP)

Thread:

Dimension package:

L 150 x W 58 x H 20 cm

Total weight:

19.4 kg

Package weight:

3.6 kg

Placing on a water-tight floor

2 year warranty

HS code:

84818011900

Approvals:

SLS BS EN 817, SS 375,
AS/NZS 4020, BS EN

